



RV GENERATORS - QUIETPACT

QP-45/55/65G

Gasoline RV Generator Sets

APPLICATIONS:

- Class A, & C Motorhomes with single or dual roof A/C
- Travel Trailers
- Sport Utility Trailers
- Fifth Wheels
- Horse Trailers
- Industrial Vehicles

Model 005753-0, 005857-0 - 4.5 kW 60Hz, Gas
Model 005751-0, 005855-0 - 5.5 kW 60Hz, Gas
Model 005752-0, 005856-0 - 6.5 kW 60Hz, Gas



FEATURES

- **INNOVATIVE DESIGN & PROTOTYPE TESTING** are key components of GENERAC'S success in "IMPROVING POWER BY DESIGN." But it doesn't stop there. Total commitment to component testing, reliability testing, environmental testing, destruction and life testing, plus testing to applicable CSA, RVIA, and other standards, allows you to choose GENERAC POWER SYSTEMS with the confidence that these systems will provide superior performance.
- **ONETOUCH START:** One touch start allows the generator to automatically prime itself and then start. If required, the generator will repeat the starting sequence automatically until the unit starts.
- **ON BOARD DIAGNOSTICS AND INDICATOR:** Equipped with self diagnosing technology, the generator indicates a potential problem through a series of blinks shown on an LED located on the generator Start/Stop switch or in the associated remote Start/Stop harness.
- **ELECTRONIC GOVERNOR CONTROL:** Electronic governor control maintains a constant engine speed of 60 Hertz to eliminate surging.
- **SOLID-STATE, FREQUENCY COMPENSATED VOLTAGE REGULATION.** This state-of-the-art power maximizing regulation system is standard on all Generac models. It provides optimized FAST RESPONSE to changing load conditions and MAXIMUM MOTOR STARTING CAPABILITY by electronically torque-matching the surge loads to the engine.
- **SINGLE SOURCE SERVICE RESPONSE** from Generac's dealer network provides parts and service know-how for the entire unit, from the engine to the smallest electronic component.
- **INDUSTRY STANDARD FOOTPRINT AND BOLT PATTERN:** Standardized air inlet and exhaust outlets, bolt patterns and wire locations allow for easy installation in any application with little or no need to modify existing enclosure accommodations.
- **UP FRONT SERVICEABILITY:** Easy access to all maintenance items including the automotive style spin-on oil filter.

GENERAC®

FEATURES

Generac RV Generator - QP-45/55/65G

ENGINE	•Generac (OHVI) Design	Maximizes engine “breathing” for increased fuel efficiency. Plateau honed cylinder walls and plasma moly rings help engine run cooler, reducing oil consumption. Because heat is the primary cause of engine wear, the OHVI has a significantly longer life than competitive engines.
	•”Spiny-lok” cast iron cylinder walls	Rigid construction and added durability provide long engine life.
	•Solid-state ignition	Provides reliable starting every time.
	•Automatic, electronic choke	Automatically assures quick and reliable starting everytime.
	•Full pressure lubrication system	Superior lubrication to all vital bearings means better performance, less maintenance and significantly longer engine life.
	•Low oil pressure shutdown system	Superior shutdown protection prevents catastrophic engine damage due to low oil.
	•High temperature shutdown	Prevents damage due to overheating. Restarts automatically once cooled for unattended operation.
	•Certifications	RVIA, CARB, EPA, U.S. Forest Service
•Evaporative port available	CARB compliant in trailer applications.	
GENERATOR	•Displaced phase excitation	Maximizes motor starting capability.
	•Automatic voltage regulation	Regulates the output voltage to ±2% prevents damaging voltage spikes.
	•Belt driven	Lowers the engine speed to reduce fuel consumption and noise levels, and to increase engine life.
	•RVIA Listed	For your safety
CONTROLS	•One touch start	Allows for generator prime and start with a single press of a button.
	•On board diagnostics	Utilizing self diagnosing technology allows for an indication of a potential generator problem.
	•Remote Start/Stop option	Allows for one touch start from any selected location inside the vehicle. Also displays on board diagnostics.
	•Main Line Circuit Breaker	Protects generator from overload.
	•Electronic governor	Maintains constant 60 Hz frequency.
UNIT	•Durable, Rhino-coated enclosure	Provides the ultimate protection against mother nature.
	•Enclosed critical grade muffler	Quiet, critical grade muffler is mounted inside the unit to prevent injuries while stationary or in transit.
	•Spark arrested exhaust	Includes a spark arrestor approved by the U.S. Forest Service.
	•Small, compact, attractive	Makes for an easy, eye appealing installation.
	•Enhanced serviceability	Up front side serviceability for performing maintenance.

SPECIFICATIONS

GENERAC®

GENERATOR	Model 05753/5857	Model 05751/5855	Model 05752/5856
Rated Maximum Continuous Power Capacity (Gasoline)	3600 Watts (900 reserve)	5500 Watts	6500 Watts
Rated Voltage	120	120	120
Rated Maximum Continuous Load Current 120 Volts	30.0 Amps	45.8 Amps	54.2 Amps
240 Volt Configurable	Yes (18.75 Amps)	Yes (22.9 Amps)	Yes (27 Amps)
Main Line Circuit Breakers	30 Amp	30 & 20 Amp	30 & 30 Amp
Phase	1	1	1
Number of Rotor Poles	2	2	2
Rated AC Frequency	60Hz	60Hz	60Hz
Power Factor	1	1	1
Engine RPM	2571	2571	2571
Rotor RPM	3600	3600	3600
Unit Weight (Pounds/Kilos)	278/126.1	285/129.3	293/132.9
Dimensions (L x W x H) inches mm	33.7 x 21.5 x 16.8 856 x 546 x 427	33.7 x 21.5 x 16.8 856 x 546 x 427	33.7 x 21.5 x 16.8 856 x 546 x 427
ENGINE	Model 05753/5857	Model 05751/5855	Model 05752/5856
Type of Engine	GENERAC OHVI V-TWIN	GENERAC OHVI V-TWIN	GENERAC OHVI V-TWIN
Number of Cylinders	2	2	2
Displacement	530cc	530cc	530cc
Cylinder Block	Aluminum w/Cast Iron Sleeves	Aluminum w/Cast Iron Sleeves	Aluminum w/Cast Iron Sleeves
Valve Arrangement	Overhead Valve	Overhead Valve	Overhead Valve
Ignition System	Solid-state w/Magneto	Solid-state w/Magneto	Solid-state w/Magneto
Governor System	Electronic Constant Speed	Electronic Constant Speed	Electronic Constant Speed
Compression Ratio	9.5:1	9.5:1	9.5:1
Starter	12 Vdc	12 Vdc	12 Vdc
Oil Capacity Including Filter (Quarts/Liters)	Approx. 1.8 Qts./1.7L	Approx. 1.8 Qts./1.7L	Approx. 1.8 Qts./1.7L
Fuel Consumption			
Gallons/Liters per hour			
10% Load	0.33/1.25	0.35/1.32	0.37/1.4
50% Load	0.45/1.70	0.55/2.08	0.65/2.46
100% Load	0.73/2.76	0.89/3.37	0.97/3.67

Generac RV Generator - QP-45/55/65G

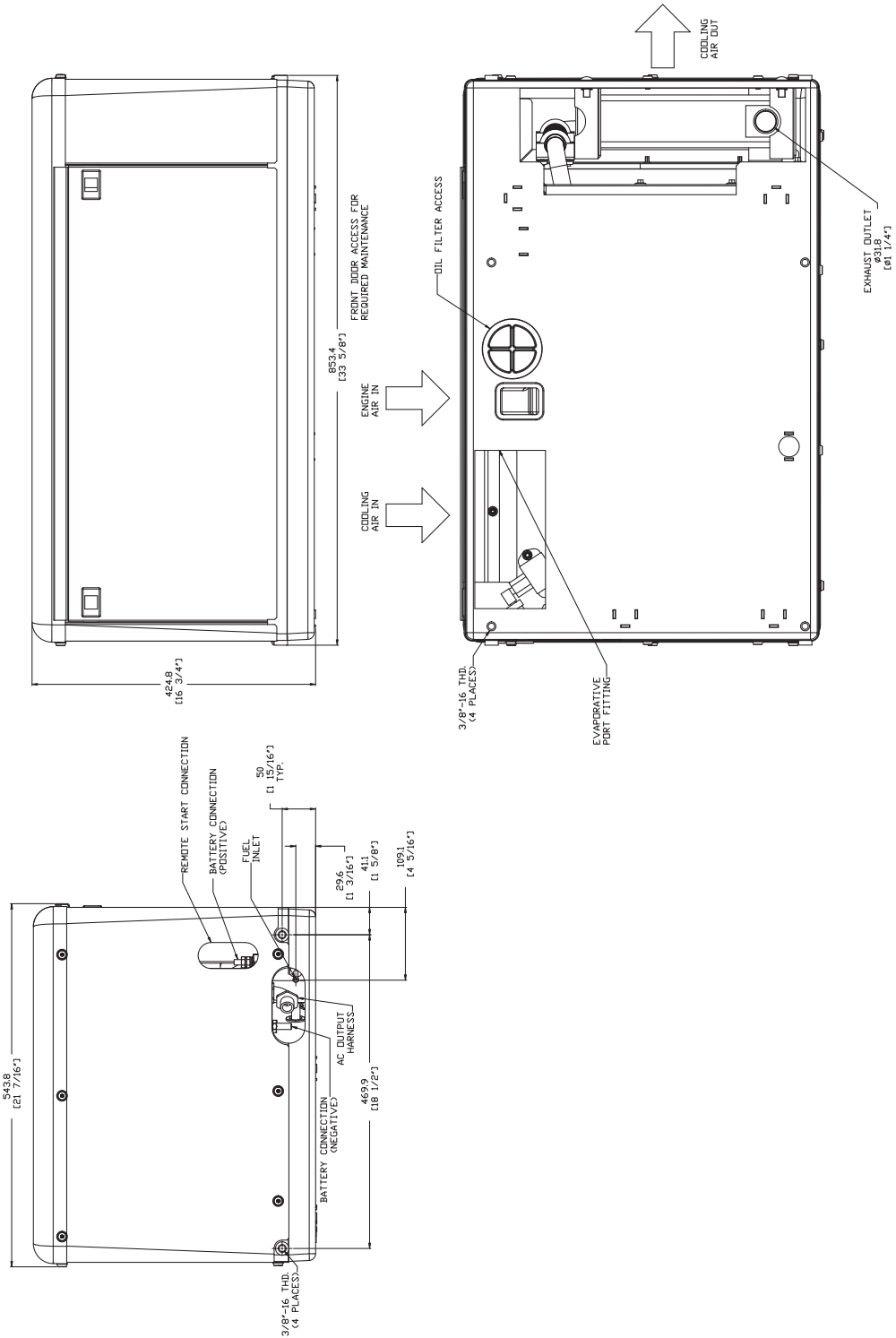

Service After the Sale

Generac's certified service organization, the largest in the industry, provides unsurpassed installation, reliable ongoing maintenance, and large inventories of parts, components, and accessories.

For RV product support please call 888-GENERAC or visit our dealer locator at www.guardiangenerators.com.

Owner's manuals (including installation, operation, maintenance and support information) are shipped with every Generac RV generator. Additional copies can be downloaded from www.generac.com.



Generac Power Systems, Inc. • S45 W29290 HWY. 59, Waukesha, WI 53189 • generac.com

©2010 Generac Power Systems, Inc. All rights reserved. All specifications are subject to change without notice. Bulletin 0181830SBY rev B / Printed in U.S.A. 01/06/10